

# Rotary Sensor

RDC80 Series



Hollow-shaft type that enables output covering the whole 360-degree angle due to adoption of the 2-phase output.



## Features

- Available for reflow soldering.
- Low-profile design 3 mm in height.

## Applications

- For controls on the onboard control panel in car etc.
- For control of home appliances
- For detection of rotation angles

Rotary Potentiometers

Slide Potentiometers

Multi Control Devices

Rotary Sensors  
Linear Sensors

Rotary Sensors

Linear Sensors

## Typical Specifications

Items	Specifications
Rating voltage	5V DC
Total resistance	10k $\Omega$
Total resistance tolerance	$\pm 30\%$
Rotational angle	360° (without stopper)
Rotational torque	10mN·m max.
Durability	100,000 cycles

## Products Line

Resistance taper (1 phase)	Linearity	Model No.	Minimum packing unit (pcs.)※
B (Linear) 100%/340°	$\pm 3\%$	RDC803001A	1,600

## Note

※ The minimum package content means the basic unit quantity for your order. Kindly determine your purchase order quantity to the "minimum package content" x N (an integral number). Meanwhile, as for the export packaging content quantity, we would like to discuss with you separately.

Dimensions

Unit:mm

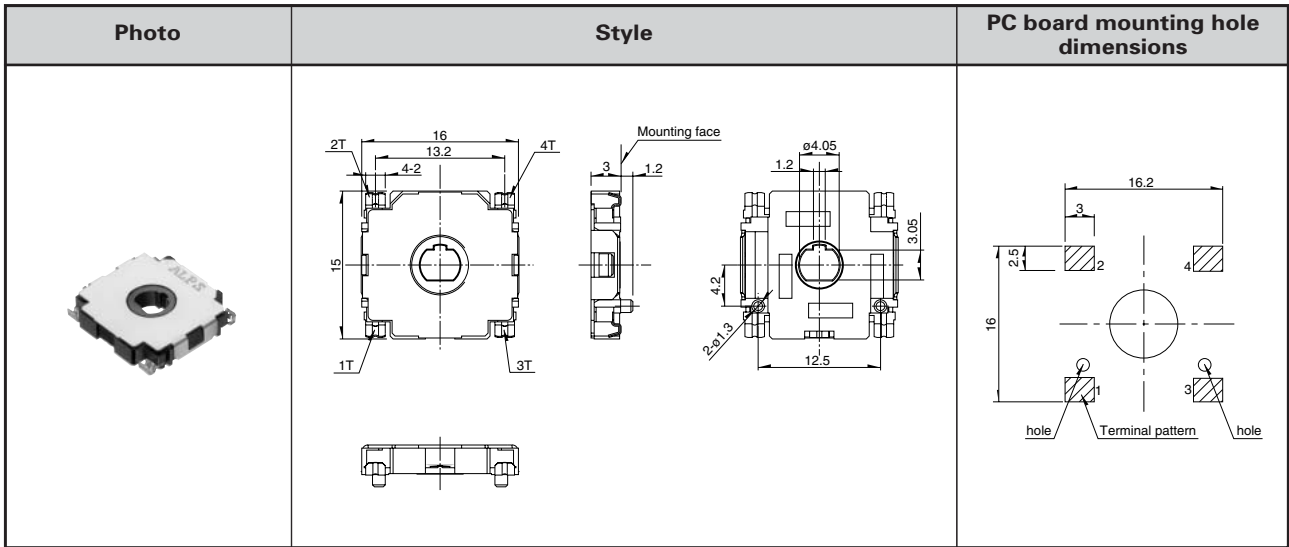

Rotary Potentiometers  
Slide Potentiometers  
Multi Control Devices  
Rotary Sensors  
Linear Sensors

Rotary Sensors  
Linear Sensors

Circuit Diagram

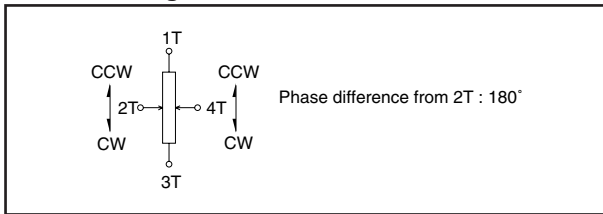

Taping Specifications

Unit:mm

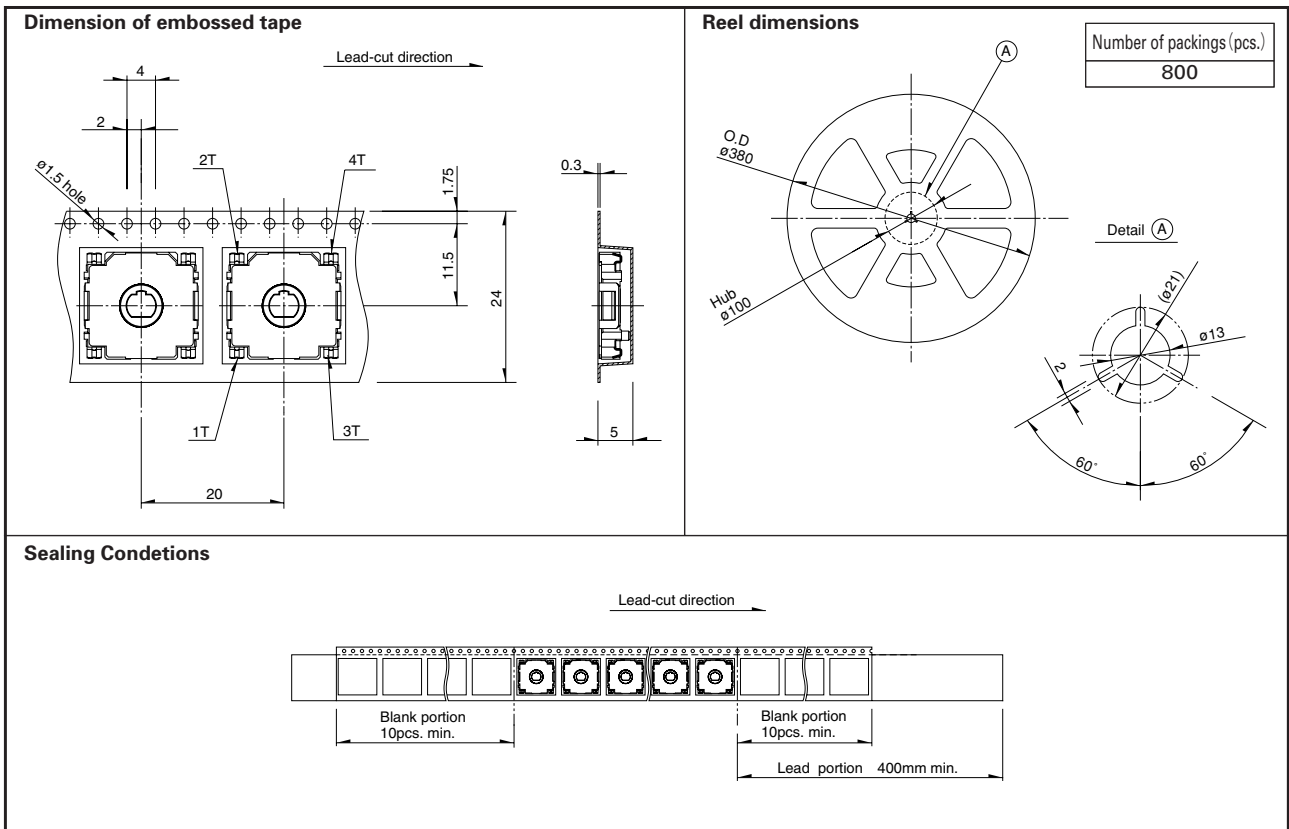

# Products Specifications

Items	Type Model	Rotary sensor						Linear sensor	
		RDC40	RDC501	RDC502	RDC503	RDC504	RDC506	RDC80	RDC10
		Multiturn type	Horizontal type	Vertical type	Reflow type	Connector type	Reflow type (Thin shape)	Reflow type	
<b>Operating temperature range</b>		-30°C to +80°C	-40°C to +120°C			-40°C to +105°C	-40°C to +120°C		-30°C to +85°C
<b>Electric performance</b>	Total resistance tolerance	±30%							
	Resistance taper	Linear							
	Rated voltage	5V DC							
	Max. operating voltage	18V DC	16V DC					5V DC	
	Linearity	±1%	±2%				±3%	±0.5%	
<b>Mechanical performance</b>	Effective variable range	13 rotations	320°				330° (1 phase) 360° (2 phase)	S (Travel) -2mm	
	Rotational angle	—	(Without stopper)					—	
	Rotational torque	2mN·m max.					10mN·m max.	—	
	Operating force	—					0.25N max.		
<b>Durability</b>	100,000 cycles	●	—				●	●	
	1,000,000 cycles	—	●				—		

Rotary Potentiometers  
Slide Potentiometers  
Multi Control Devices  
Rotary Sensors  
Linear Sensors

Rotary Sensors  
Linear Sensors

## Method for Regulating the Linearity

### Model RDC40

- Reference taper : 90%/13 rotations
- V<sub>A</sub> is measured output value

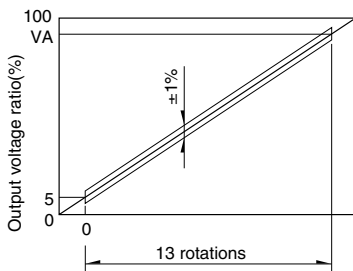

### Model RDC50

- Reference taper : 100%/333.3°
- Output level of reference point is 50% .

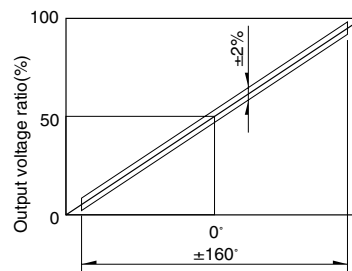

### Model RDC80

- Reference taper : 100%/340°
- The center position depends on the position depicted in the product drawing.

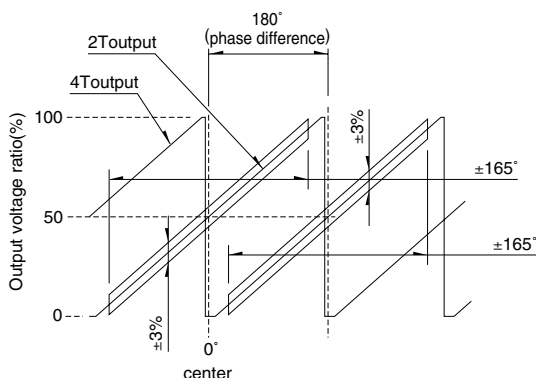

### Model RDC10

This is the deviation to an ideal line shown below when the voltage applied between terminals 1 and 3 is assumed to be 100%. (Unit:percentage)  
With rated voltage applied between terminals 1 and 3, the ideal line is assumed to be the straight line drawn between the measured output values V<sub>B</sub> and V<sub>A</sub> at specified reference positions B and A.

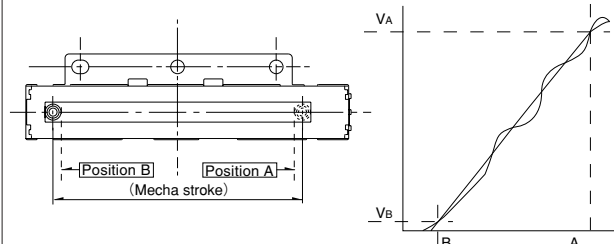

## Soldering Conditions

### Soldering Conditions

#### 1. Recommended reflow conditions

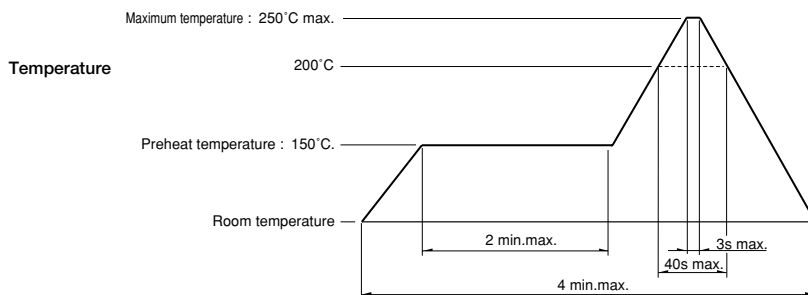

2. Cleaning Cleaning should not be attempted.
3. Type of solder to be used Use cream solder that contains 10 - 15 %wt flux.
4. No. of soldering: Soldering should be done just once.

### Notes

1. When using an infrared reflow oven, solder may sometimes not be applied. Be sure to use a hot air reflow oven or a type that uses infrared rays in combination with hot air.
2. The temperatures given above are the maximum temperatures at the terminals of the potentiometer when employing a hot air reflow method. The temperature of the PC board and the surface temperature of the potentiometer may vary greatly depending on the PC board material, its size and thickness. Ensure that the surface temperature of the potentiometer does not rise to 250°C or greater.
3. Conditions vary to some extent depending on the type of reflow bath used. Be sure to give due consideration to this prior to use.

## Caution

### [Use of Chemicals]

Polymers such as polycarbonate are applied in the sensor. Do not use the product under dense atmosphere of ammonia, amines, alkali solution, aromatic hydrocarbon, ketenes, esters, homogenous hydrocarbons, etc.

### [Noise Issue]

While data is being received from the sensor, output signal may be disturbed due to some external noise etc.

To minimize this situation, the following way of measurement is recommended:

E.g.) Data should be acquired several times and averaged. Also, data which is supposed to be acquired erroneously should be ignored and measured again. Repeat these steps.

### [Soldering]

Avoid wiring and soldering that cause solder to flow out to the top of a PC board as shown. A contact failure may occur in the terminal portion. When this kind of circuit layout is needed, consult us in advance.

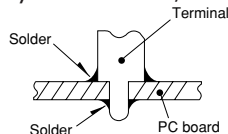

## Analog Output Contact Type

### [Connection Impedance]

The contact resistance (R1) in this sensor is set to a high level because its output terminal is designed to directly connect to the A/D port of the microprocessor.

Consequently, set the connection impedance (R2) to 1M ohm or more to eliminate the influence of the contact resistance (R1).

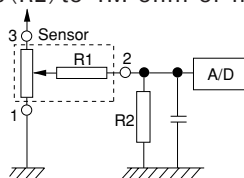

### [Condensation]

Avoid using the sensor under the conditions where condensation might occur or water drops might adhere to the resistor surface of the sensor. Insulation deterioration or shorting may occur.